

Finishing A Quilt with Straight-Cut Binding

There are many binding options available to the quilter. In this tutorial, we will focus on a simple, straight-cut binding applied to a straight-edged, rectangular quilt that has an outer border.

There are no steadfast rules for how to bind quilted projects. Some quilters forego the binding altogether and just fold the backing over to the front of the quilt and slip-stitch in place. In this tutorial, we will focus on how to apply continuous, straight-cut, binding to the edges of a straight-edged, rectangular quilted project. Straight-cut binding is cut either across the width (perpendicular to the selvage) or along the length (parallel to the selvage) of the fabric yardage.

Preparing the Quilt

It's important to prepare your quilt before applying the binding.

Once quilted, a quilt may no longer be perfectly square at the corners. Also, depending on the density of the quilting and how close the quilting is to the sides, the long sides may no longer be perfectly straight. It's important to either straighten the sides and square-up the corners before applying the binding, or to draw a guideline for adding your binding. There are a number of ways to do this:

For a quilt with a border:

Lay the quilt out on a level surface and smooth it out with your hands. Use a ruler and a chalk pencil to mark the outer edge of the quilt, making sure that the border is the same width all around the quilt and that the corners form a perfect 90-degree angle. It's okay if the border was supposed to be 3", but you end up with a 2 3/4" border all around. What's important is that the border is the same width all around, the sides are about the same length, and the top and bottom are about the same width.

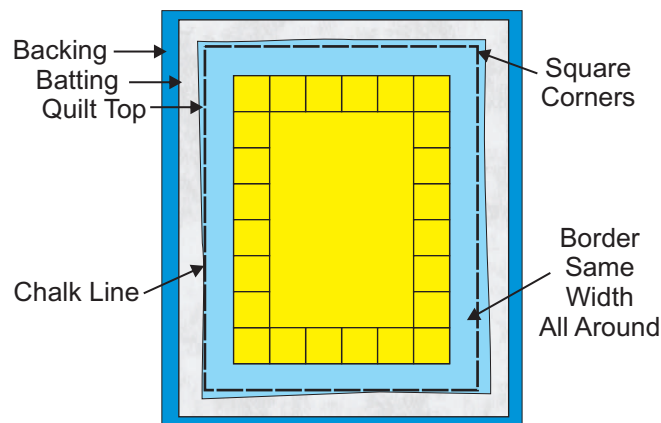

Note that the larger the quilt, the more likely it is that your sides won't be the same length and that the top and bottom won't be the same length. You can use your hands to "block" the quilt into shape as much as possible before marking and trimming. If the quilt is not for a show or judging, don't fret too much. Just make sure the border looks balanced all around the quilt and that the corners are as close to 90-degrees as possible.

At this point, you can trim away the excess top, batting, and backing, along the chalk line. Or, you can leave it in place and use the chalk line to position the raw edge of the binding and trim off the excess later.

How Much Binding is Needed?

To calculate the length of binding you need, add the length of all four sides of the quilt. Then add another 8" for each join you will need to make when sewing the strips together.

Preparing the Binding

For projects that will not get a lot of wear and tear, like wall hangings, you can use single-layer binding. For projects that will be washed regularly or receive more wear and tear (like table runners, placemats, baby quilts, throws, and bed quilts) double-layer binding is a better choice.

Single-layer binding can be made from 1 1/4" - 1 1/2" wide strips cut across the width or the length of your fabric yardage. For double-layer binding cut 2 1/4" to 2 1/2" strips.

Once the strips are cut, sew them together, on the bias, to form a continuous binding strip. To do this, lay the end of one strip right side up. Lay the end of a second strip right side down over the first such that 1/4" of each strip hangs over, as shown below.

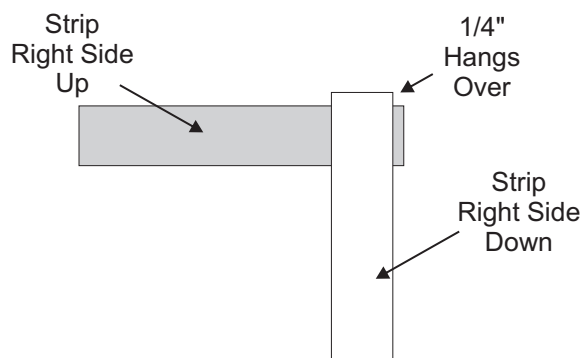

Finishing A Quilt with Straight-Cut Binding

Sew the strips together on the diagonal from edge to edge, as shown.

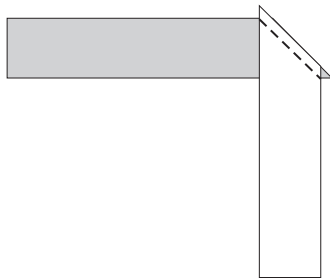
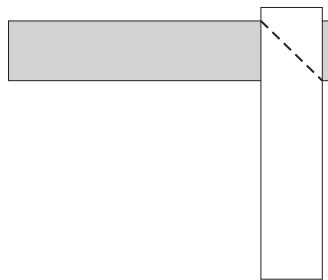

Trim off the excess leaving a 1/4" seam allowance, as shown. Press the seam open.

Sew enough strips together to create a continuous binding strip of the length required.

If you are making double-layered binding, fold the binding in half, wrong sides together along the length, and press.

Applying the Binding to the Quilt

Lay the quilt with the right side facing up. Beginning on one side, with right sides together, align the raw edge of the binding with the raw edge of the quilt. As shown below, sew the binding in place with a 1/4" seam allowance, starting 6" - 8" from the end of the binding and stopping 1/4" from the corner. Backstitch. Pull the quilt out from under the presser foot and cut the thread.

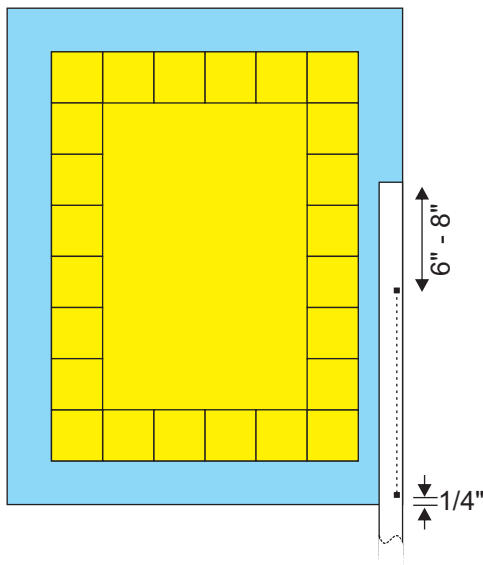

To make a neat mitered corner, turn the quilt 90-degrees to the left. Fold the binding up creating a 45-degree fold at the corner, as shown below.

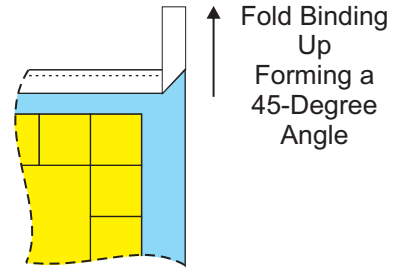

Then fold the binding down, aligning the fold with the first edge and aligning the raw edge of the binding with the adjacent raw edge of the quilt, as shown below. Sew the binding in place with a 1/4" seam allowance, starting at the edge and stopping 1/4" from the opposite corner.

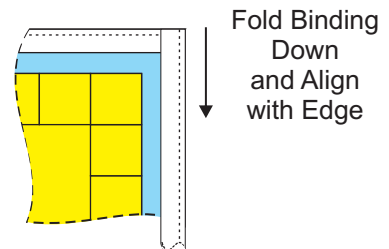

Continue sewing on the binding, mitering the remaining corners as described above.

Stop sewing 8" from the point where you started.

Lay the quilt right side up, flat on a table, and butt the two ends of the binding together in the middle of the unsewn section. Flop the binding to the right, keeping the two ends butted together. Using a ruler and chalk pencil, draw a line across the binding exactly where the two ends meet, as shown below. Flop the excess binding to the left and keeping the binding butted together, draw a line across the other end of the binding exactly where the two ends meet.

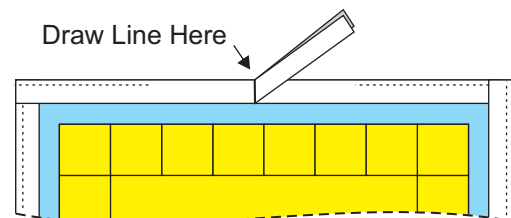

Finishing A Quilt with Straight-Cut Binding

If you are using double-fold binding, open the binding and draw the line completely across, keeping it perpendicular to the edge.

Draw a duplicate chalk line, in the same location, on the reverse side of each of the binding ends.

Now fold the quilt in half across the center so that the two ends of the binding are free.

Place the two ends of the binding, right sides together, perpendicular to each other, aligning the chalk lines, as shown below. Pin in place.

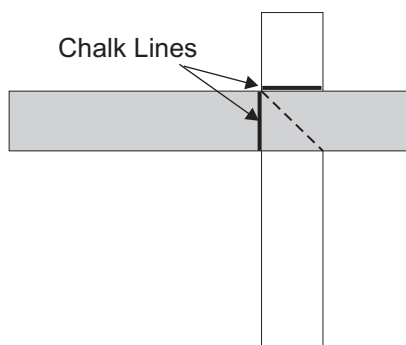

Sew the two ends of the binding together at a 45-degree angle, as shown above. **Do not trim yet.**

Unfold the quilt and lay flat on a table. Test fit the binding and adjust the stitching if needed.

When you are satisfied with the fit, trim off the excess binding leaving a 1/4" seam allowance. Press the seam open.

If you are using double-fold binding, re-fold as before and press.

Align the raw edge of the binding with the raw edge of the quilt and finish sewing the binding in place.

Gently fold the binding over the seam toward the raw edge and press.

Flip the quilt over to the back and fold the binding to the back, making sure it covers the seam. Press.

At the corners, make neat miters using a 45-degree fold as you did on the front and press.

Using thread that matches the binding, blind stitch the binding down using a single strand of thread, being careful not to let the thread show on the front of the quilt. We like to use about 18" of thread at a time, securing it at the beginning and end with a knot. That way if a thread breaks later, the entire binding will not come undone.

You can also machine-stitch the binding in place. This technique takes some practice to produce an even stitch along the binding on the back.

To machine-stitch the binding down, make sure the binding extends at least 1/8" beyond the seam line on the back. From the front, pin the binding in place, in the ditch, catching the binding in the back. From the front, sew in the ditch as close to the binding as possible, catching the folded edge of the binding in the back. Remove the pins as you go.

Be sure to also blind stitch the 45-degree folds on the mitered corners on both the front and the back of the quilt.